

Main Specifications

▼ Type

Lever type / Seal type

▼ Pressure range

0.1 to 20 kg/cm²

▼ Operating temperature

Min.: -196°C

Max.: 350°C

▼ Applicable fluid

Steam / air / liquid that compatible with Stainless steel

Stainless Steel Safety Valve

Model: SSV-S20 Series

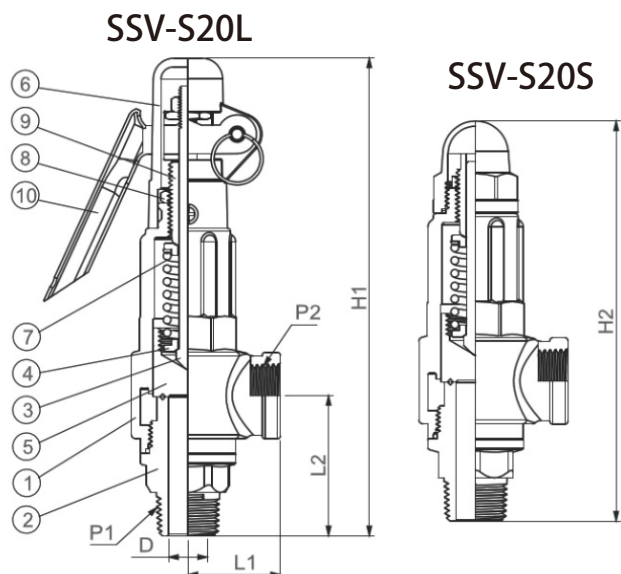

Due to the variety of customization, the picture is only for reference, please confirm the actual item with our sales. (If there is any change on specification, please take the latest version as standard.)

Material Table

No.	Name	SSV-S20L Lever type	SSV-S20S Seal type
1	Valve Body	CF8 / CF8M	CF8 / CF8M
2	Valve Seat	CF8 / CF8M	CF8 / CF8M
3	Stem	SS304	SS304
4	Spring Seat	SS304	SS304
5	Disc	SS304 / SS316	SS304 / SS316
6	Cap	CF8	CF8
7	Spring	SS304	SS304
8	Nut	SS304	SS304
9	Adjust Screw	SS304	SS304
10	Handle	SS304	SS304
Operating temperature		-196°C~350°C	

Dimension

P1	D	P2	Lift	L1	L2	H1	H2
1/2"	13	1/2"	1.04	31	46.95	160.1	134.1
3/4"	19	3/4"	1.52	34.8	56.4	172.5	147
1-1/4"	30	1-1/4"	2.56	52	73	218.2	197.7
1-1/2"	34	1-1/2"	3.04	59.5	89	347.3	226.8

Unit : mm